

MT 36 Bp

Our MT 36 Bp battery powered multi-tool is a drive unit that can have different ends mounted to it, from pole hedge trimmers to pole pruners. For a variety of tasks with just one machine.

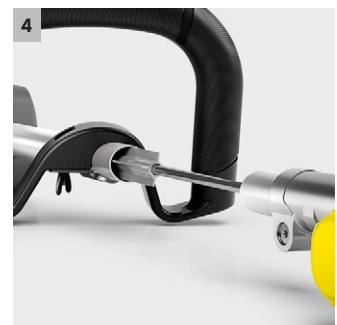
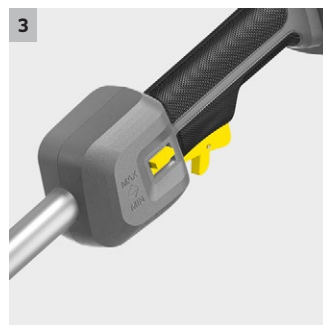

1 Convenient quick coupling

- Change attachments easily, quickly and without any tools.
- Compact and easy to transport and store.

2 Ergonomic, round grip

- Enables you to work in comfort.
- Can be individually adjusted for each user.

3 Variable speed

- Can be adapted to the particular usage.
- Extended runtime.

4 Solid, smooth steel shaft

- Robust design.
- Durable components.



MT 36 Bp

- Brushless motor
- Quick coupling for easy tool changes
- Variable rotation speed for use in any situation

Technical data

Order no.	1.042-511.0	
EAN code	4054278635965	
Battery platform	36 V battery platform	
Rotational speed	rpm	7800 / 6800
Voltage	V	36
Weight without accessories	kg	2,6
Weight incl. packaging	kg	3,62
Dimensions (L × W × H)	mm	950 × 190 × 170

Equipment

Round rubber grip	■
Shoulder belt	■
Quick coupling	■

■ Included in delivery.

MT 36 BP 1.042-511.0

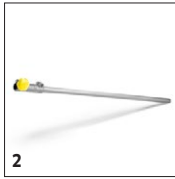

		Order no.					Price	Description	
Machine accessories									
Shoulder belt universal	1	2.042-016.0							<input checked="" type="checkbox"/>
MT EXT 100	2	2.042-031.0							<input type="checkbox"/>

Included in delivery.
 Available accessories.

MT 36 BP 1.042-511.0



		Order no.					Price	Description	
Batteries									
Accumulator special accessories 36V 5,0	1	2.445-031.0							<input type="checkbox"/>
Batteries									
Battery Power+ 36/75	2	2.445-043.0							<input type="checkbox"/>
Battery Power+ 36/60	3	2.042-022.0							<input type="checkbox"/>

■ Included in delivery. □ Available accessories.